

PV-CM

CHAIN MOUNT

Table 1: Base Kits

Part Number	Description	Weight (lbs)
PV-CM1	Single Sector Chain Mount, 8ft Chain	33.6
PV-CM1L	Single Sector Chain Mount, 16ft Chain	44.3
PV-CM1S-ADD	Single Sector Chain Mount Add On	15.2

Table 2: Combined Kits

Part Number	Description	Weight (lbs)	Included Parts			
			PV-CM1	PV-CM1L	PV-CM1S-ADD	PV-PM412X63
PV-CM2	2 Sector Chain Mount, 8ft Chain	45.5	1	-	1	-
PV-CM2L	2 Sector Chain Mount, 16ft Chain	56.1	-	1	1	-
PV-CM3	3 Sector Chain Mount, 8ft Chain	60.6	1	-	2	-
PV-CM3L	3 Sector Chain Mount, 16ft Chain	71.3	-	1	2	-
PV-CM6	6 Sector Chain Mount, 8ft Chain	106.0	1	-	5	-
PV-CM6L	6 Sector Chain Mount, 16ft Chain	116.8	-	1	5	-
PV-CM1-412X63	Single Sector Chain Mount, 8ft Chain, 4.5" Pipe Mount	97.2	1	-	-	1
PV-CM1-HD-412X63	Single Sector Chain Mount, Double 8ft Chain, 4.5" Pipe Mount	127.5	2	-	-	1

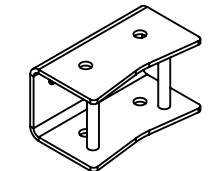
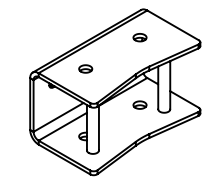
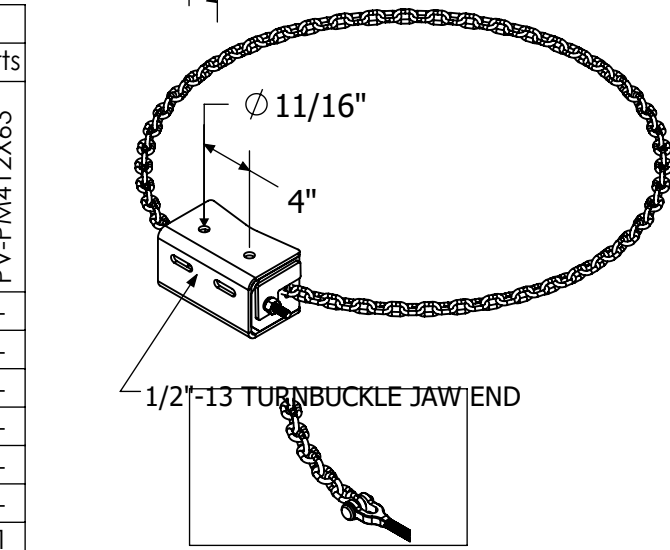
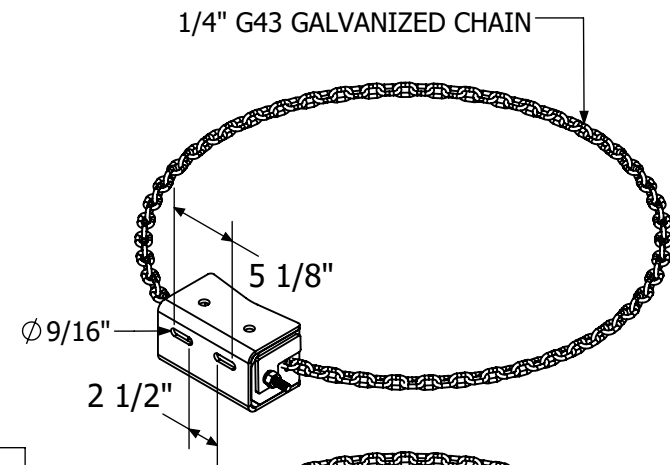

PV-CM1S-ADD
CHAIN MOUNT ADD ON

SINGLE SECTOR CHAIN MOUNT
PV-CM1 SHOWN

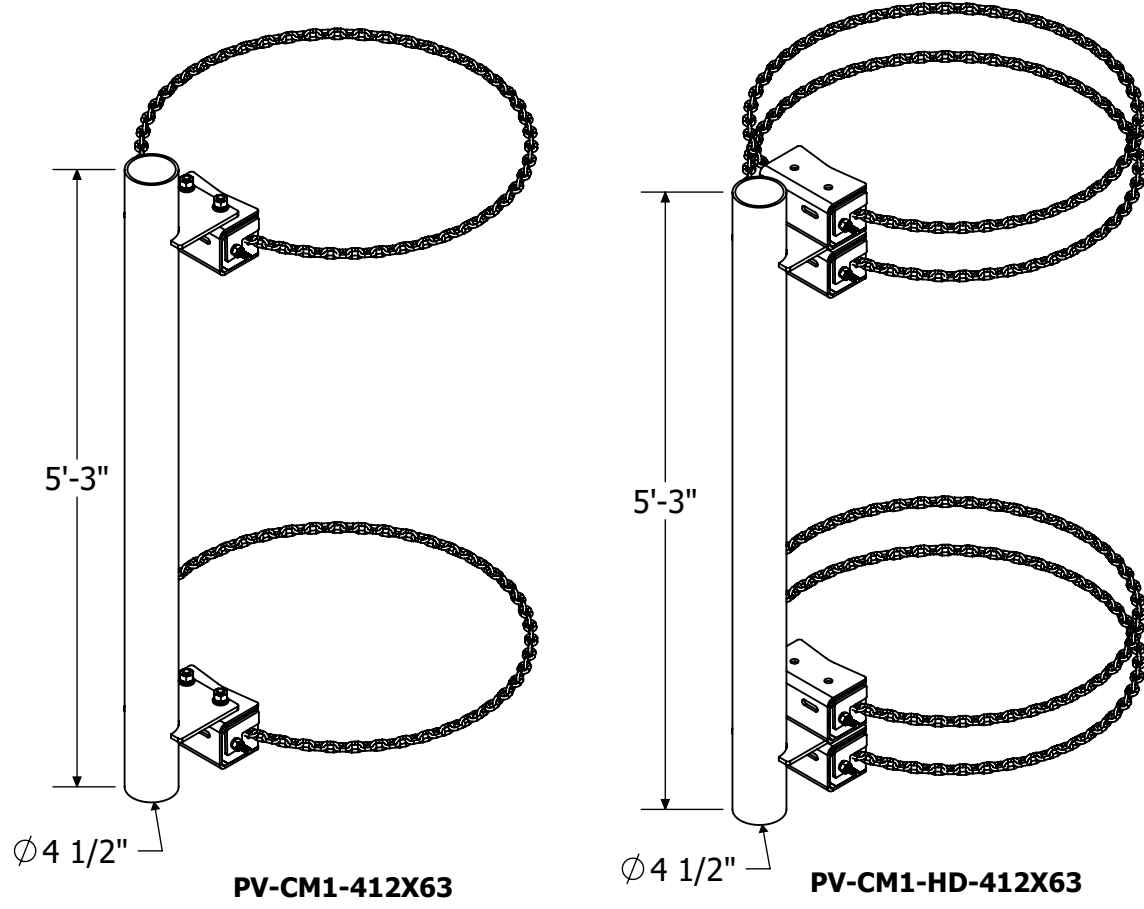

PV-CM1-412X63

PV-CM1-HD-412X63

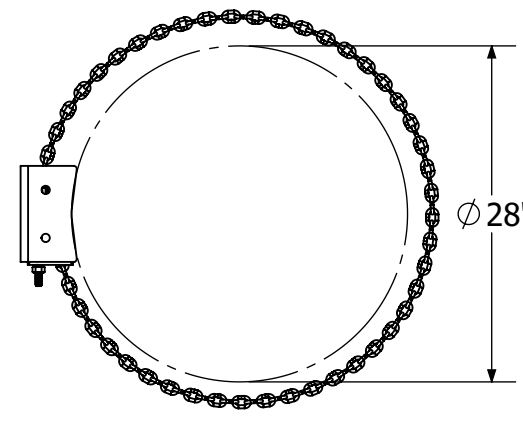

8FT CHAIN

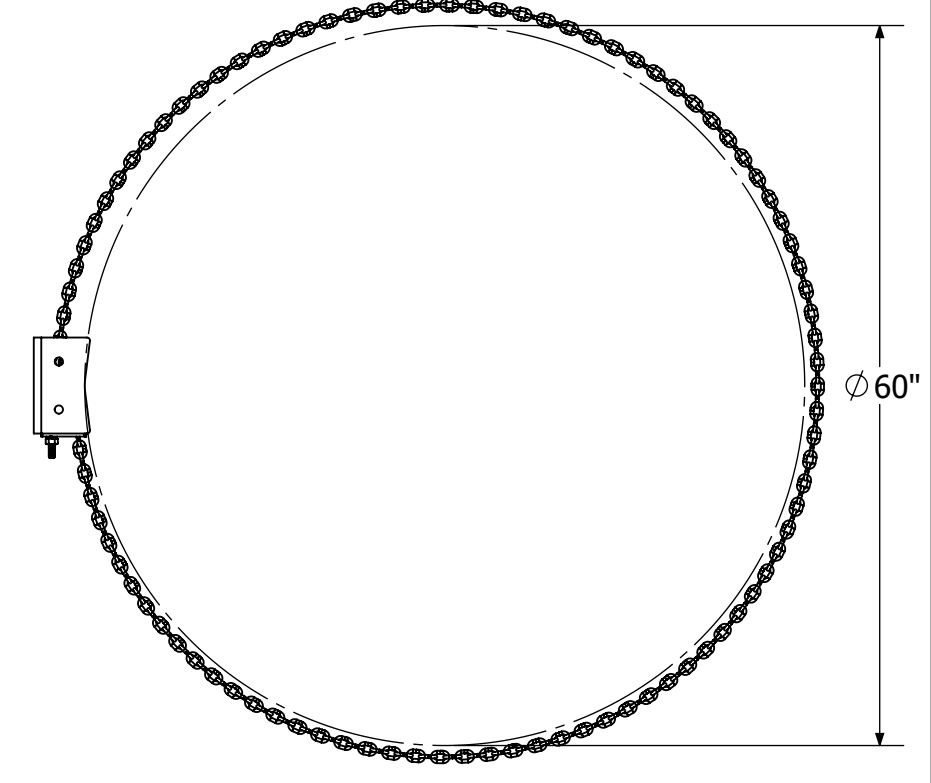

16FT CHAIN

SHEET	THIRD ANGLE PROJECTION	CATEGORY	4		
1 OF 1		02_Monopole	4		
		SERIES	10_Chain Mounts	3	
8/21/2020	SCALE 1:16	TYPE	PV-CM_Chain Mount	2	E&O TEMPLATE UPDATE 8/20/20
DIMENSIONS ARE IN INCHES TOLERANCES U.N.O. HOLES: +1/16", -1/32" ANGULAR: PROFILE ± 1/4°, BEND ± 2° ALL OTHERS: ± 1/16"		BY	INT	1	ADDED MASTER ASSEMBLIES 2/9/16
		CHECKED		0	INITIAL RELEASE 7/20/15
		STATUS	APPROVED	REV	DESCRIPTION
					CHAIN MOUNT DOCUMENT NUMBER CM-ENG-01-R2
					REV 2

C:\PV\Steel\Catalog\SW Working Files\Engineering Details\