

**Andrew Solutions**  
**VHLP3-11W****1.0 m | 3 ft ValuLine® High Performance Low Profile Antenna, single-polarized,  
10.125–11.700 GHz**

## General Specifications

Antenna Type	VHLP - ValuLine® High Performance Low Profile Antenna, single-polarized
Diameter, nominal	1.0 m   3 ft
Polarization	Single

## Electrical Specifications

Beamwidth, Horizontal	2.0 °
Beamwidth, Vertical	2.0 °
Cross Polarization Discrimination (XPD)	30 dB
Electrical Compliance	Brazil Anatel Class 2   Canada SRSP 310.5   ETSI 302 217 Class 3   US FCC Part 101A @ 10.55–10.7 GHz   US FCC Part 101A @ 10.7–11.7 GHz   US FCC Part 101B @ 10.125–11.7 GHz
Front-to-Back Ratio	64 dB
Gain, Low Band	37.2 dBi
Gain, Mid Band	38.4 dBi
Gain, Top Band	39.0 dBi
Operating Frequency Band	10.125 – 11.700 GHz
Radiation Pattern Envelope Reference (RPE)	7164   7166
Return Loss	17.7 dB
VSWR	1.30

## Mechanical Specifications

Fine Azimuth Adjustment	±15°
Fine Elevation Adjustment	±15°
Mounting Pipe Diameter	115 mm   4.5 in
Net Weight	24 kg   53 lb
Side Struts, Included	0
Side Struts, Optional	1 inboard
Wind Velocity Operational	200 km/h   124 mph
Wind Velocity Survival Rating	250 km/h   155 mph

## Wind Forces At Wind Velocity Survival Rating

Angle $\alpha$ for MT Max	0 °
Axial Force (FA)	2979 N   670 lbf
Side Force (FS)	936 N   210 lbf
Twistina Moment (MT)	1184 N•m

# Product Specifications

VHLP3-11W



Weight with 1/2 in (12 mm) Radial Ice	46 kg		101 lb
Zcg with 1/2 in (12 mm) Radial Ice	220 mm		9 in
Zcg without Ice	324 mm		13 in

VHLP3-11W



## Wind Forces At Wind Velocity Survival Rating Image

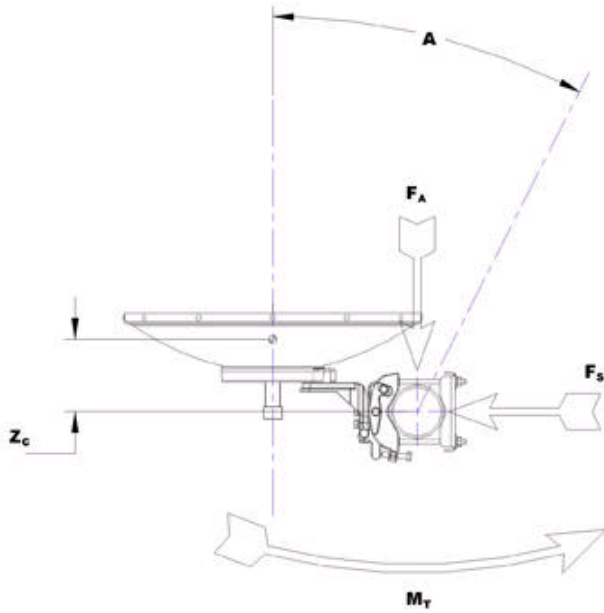

## Antenna Dimensions And Mounting Information

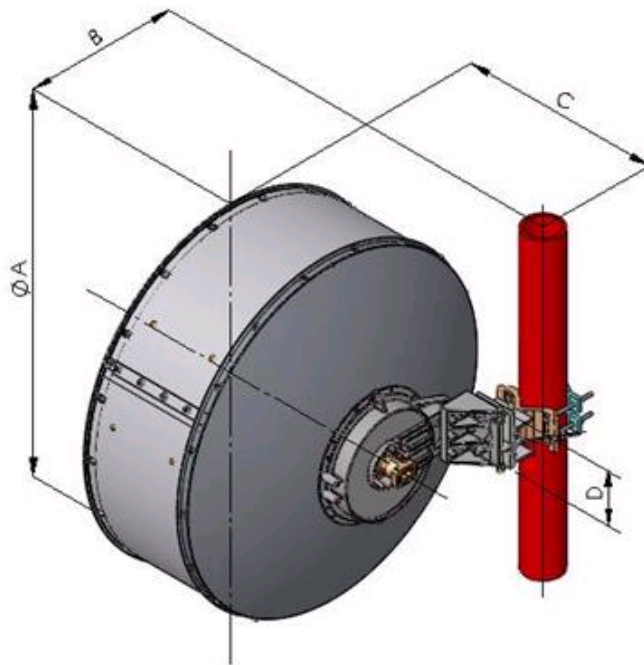

Dimensions in Inches (mm)				
Antenna Size, ft (m)	A	B	C	D
3(0.9)	39.4 (1000)	17.5 (445)	24.3 (617)	6.3 (160)

### \* Footnotes

Axial Force (FA)	Maximum forces exerted on a supporting structure as a result of wind from the most critical direction for this parameter. The individual maximums specified may not occur simultaneously. All forces are referenced to the mounting pipe.
Cross Polarization Discrimination (XPD)	The difference between the peak of the co-polarized main beam and the maximum cross-polarized signal over an angle twice the 3 dB beamwidth of the co-polarized main beam.
Front-to-Back Ratio	Denotes highest radiation relative to the main beam, at $180^\circ \pm 40^\circ$ , across the band. Production antennas do not exceed rated values by more than 2 dB unless stated otherwise.
Gain, Mid Band	For a given frequency band, gain is primarily a function of antenna size. The gain of Andrew antennas is determined by either gain by comparison or by computer integration of the measured antenna patterns.
Operating Frequency Band	Bands correspond with CCIR recommendations or common allocations used throughout the world. Other ranges can be accommodated on special order.
Radiation Pattern Envelope Reference (RPE)	Radiation patterns determine an antenna's ability to discriminate against unwanted signals under conditions of radio congestion. Radiation patterns are dependent on antenna series, size, and frequency.



VHLP3-11W

Return Loss	The figure that indicates the proportion of radio waves incident upon the antenna that are rejected as a ratio of those that are accepted.
Side Force (FS)	Maximum side force exerted on the mounting pipe as a result of wind from the most critical direction for this parameter. The individual maximums specified may not occur simultaneously. All forces are referenced to the mounting pipe.
Twisting Moment (MT)	Maximum forces exerted on a supporting structure as a result of wind from the most critical direction for this parameter. The individual maximums specified may not occur simultaneously. All forces are referenced to the mounting pipe.
VSWR	Maximum; is the guaranteed Peak Voltage-Standing-Wave-Ratio within the operating band.
Wind Velocity Operational	The wind speed where the antenna deflection is equal to or less than 0.1 degrees. In the case of ValuLine antennas, it is defined as a maximum deflection of 0.3 x the 3 dB beam width of the antenna.
Wind Velocity Survival Rating	The maximum wind speed the antenna, including mounts and radomes, where applicable, will withstand without permanent deformation. Realignment may be required. This wind speed is applicable to antenna with the specified amount of radial ice.