

FP1-5-24

0.3 m | 1 ft Flat Panel Antenna, Single-polarized, 5.15-5.85GHz



General Specifications

Antenna Type	Flat Panel Antenna
Size, nominal	1 ft 0.3 m
Polarization	Single

Electrical Specifications

Operating Frequency Band	5.15 - 5.85 GHz
Half Power Beamwidth, Horizontal	30 degrees
Half Power Beamwidth, Vertical	30 degrees
Cross-Polarization Discrimination	30 dB
Front to Back Ratio (F/B)	40 dB
Gain, Low Frequency	23.4 dBi
Gain, Mid Frequency	24 dBi
Gain, High Frequency	24.5 dBi
VSWR	1.4:1
Return Loss	-15.5 dB

Mechanical Specifications

Fine Azimuth Adjustment	Supplied with coarse az adjust only
Fine Elevation Adjustment	+/- 10 degrees
Mounting Pipe Diameter, Min	2 inch 5.1 cm
Mounting Pipe Diameter, Max	2.5 inch 6.4 cm
Net Weight	5 lbs 2.3 kg
Wind Velocity Operational	90 mph 145 km/h
Wind Velocity Survival Rating	125 mph 201 km/h
Mechanical Configuration	FP1
Axial Force (FA)	49 lbs 220 N
Side Force (FS)	0 lbs 0 N
Twisting Moment (MT)	0 ft-lbs 0 Nm
Operating temperature range	-40 to +60 C
Max pressure, psig, (if waveguide interface)	na

Regulatory Compliance

FCC	undeclared
ETSI	undeclared
RoHS-complaint	Yes

Shipping Information

Package Type	Cardboard
Gross Weight	8 lbs 3.6 kg
Dimensions, L x W x H	16 x 16 x 5in 40 x 40 x 12 cm
Shipping Volume	0.7 cu ft 0.02 cu m

Additional Comments

Choose Radiowaves products for best performance and reliability

Technical Drawings

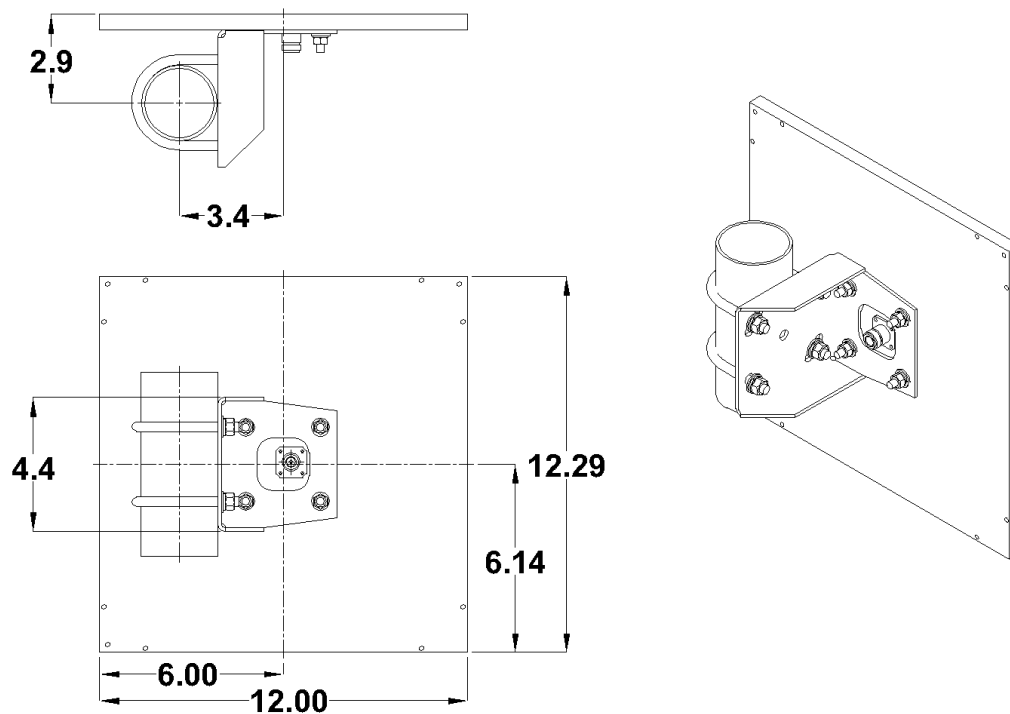

FP1

Radiowaves Glossary

Axial Force:	Force applied to the face of the antenna due to wind at specified wind speed
Beamwidth	The total width of the main beam measured in degrees between the 3-dB (half-power) points on either side of the peak of the main beam
Cross Polarization Discrimination (XPD)	The dB difference between maximum received co-polarized signal at electrical boresight and maximum received cross-polarized signal
Front to Back Ratio (F/B)	The dB difference between maximum received signal at electrical boresight to maximum received signal behind the antenna (180 +/- 40 degrees)
Gain	A measure of how well the antenna focuses available energy into a single beam. Larger antennas typically have higher gains and smaller beamwidths.
Gross Weight	Shipping weight, includes weight of antenna plus packaging materials
Net Weight	Weight of antenna only as mounted on tower.
Operating Frequency Band	The frequency limits between which the antenna meets declared specifications. Antennas may operate outside the frequency band with mild performance degradation.
Return Loss	A measure of how much rf energy incident upon the antenna is reflected back from whence it came, expressed as a negative dB value.
Side Force (FS)	Force applied to the side of the antenna due to wind at specified wind speed
Twisting Moment (MT)	The torsional (twisting) moment (force x distance) applied to the mounting pipe due to wind at the specified wind speed.

VSWR	A measure of how much rf energy incident upon the antenna is reflected back from whence it came, expressed as a ratio
Wind Velocity Operational	Wind speed where the antenna deflection is less than or equal to 0.1 degrees
Wind Velocity Survival Rating	Wind speed where the antenna will not suffer permanent damage, but may require re-pointing.