



## CAT6 Shielded Bulkhead Coupler, Water Sealed, Outdoor RJ45

Primus Cable's Industrial Grade Outdoor Female-Female Couplers are the perfect option for your networking applications that require equipment to be in wet or debris-filled environments. Our Outdoor Industrial Couplers mount flush against the wall plate and create a watertight seal. The Industrial Outdoor Couplers are ideal for protecting electrical equipment in the most messy of environments. Additionally, these Shielded Industrial Couplers are compatible with our Outdoor Industrial Wall Plates and are IP67 rated.

### Features

- Shielded CAT6 Keystone Jack
- Water Tight & Dust Tight Seal
- Industrial Grade - IP67 Rated
- Flush Mount
- 50 micron Gold Plated Contact Pin
- RoHs Compliant

### Material

- Main Body: PBT+GF, UL94V-0
- Shielded Case: Brass, Nickel Plated
- Coupler Housing: ABS, UL94V-0
- Jack Contacts: Phosphor Bronze, 50U" Gold Plated

### Physical Characteristics

- Insertion Life: 750 Mating Cycles w/ FCC Comp 8P Plug
- Contact Force: 100 Grams w/ FCC Comp 8P Plug
- Plug Retention Force: 11LBF Min.
- Operating Temperature Range: -10°C - 60°C
- Storage Temperature Range: -40°C - 68°C
- Humidity: 10% - 90 % RH

### Electrical

- Insulation Resistance: 500 MΩ
- Dielectric Withstanding Voltage: 1000 V AC
- DC Current Rating: 1.5 Amps
- DC Resistance: 0.1 Ω
- Contact Resistance: 20 mΩ

**CAT6**

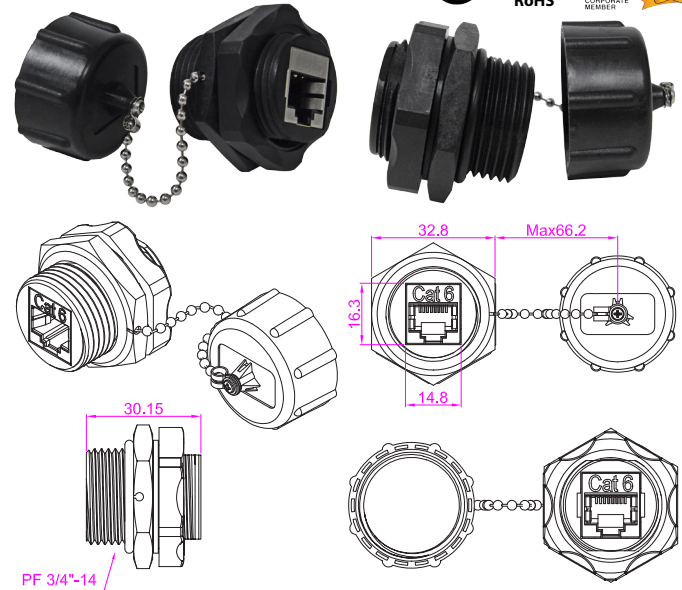

### Compliance

- ANSI/TIA-568-C.2
- ISO/IEC 11801 2nd Edition
- IEC 60603-7
- IP67 Rated

### Item Number

- Black Item# K65-1515-IP-SH

### Optional CAT6 Bulk Cables

- C6CMX-2043BK - CAT6 Outdoor Bulk Ethernet Cable, Solid Copper UL Listed UTP CMX, 23 AWG

Primus Cable's UL Listed Outdoor Unshielded CAT6 cable is the perfect fit for installations where the cable will be outside and above ground. This cable's 8 conductors are solid bare copper with a HDPE insulation and a CMX rated PVC Jacket. Our Category 6 CMX Rated Outdoor Cable is designed for residential outdoor LAN applications and is resistant to cracking after long-term UV exposure, making it the best solution for installation runs that require the cable to be exposed to the elements. To complete your installation call us about our tools.



- C6CMXR-1069BK - CAT6 Outdoor Bulk Ethernet Cable, Shielded CMX/CMR, 23 AWG 1000FT

Primus Cable's Shielded, Indoor/Outdoor, CAT6, UV Resistant cable features 8 conductors of solid bare copper with a HDPE insulation and a CMX/CMR rated Jacket. Our Category 6, Shielded, CMX/CMR Cable is designed for residential indoor and outdoor LAN applications and is resistant to cracking after UV exposure, making it the ideal solution for installation runs that require the cable to be exposed to the elements. Our Shielded CAT6 Indoor/Outdoor cable is tested to perform up to speeds of 600MHz.



- C6CMXT-2045BK - CAT6 Outdoor Bulk Ethernet Cable, Direct Burial Shielded Solid Copper, Waterblock Tape, 23 AWG

Primus Cable's Shielded Outdoor Waterblock Tape Direct Burial CAT6 Cable is the perfect fit for installations where the cable will be buried under ground in conduit. This cable's 8 conductors are solid bare copper with a HDPE insulation and a LDPE Jacket. This cable also includes an aluminum foil shielding which helps eliminate and protect against EMI. For added moisture protection this cable includes a waterblock tape that repels water keeping it out of the cable and away from the conductors. This cable is tested to perform up to speeds of 600MHz.



PrimusCable.com - (951) 824-1571



## CAT6 Shielded Bulkhead Coupler, Water Sealed, Outdoor RJ45

### Optional Cable Management

#### CAT6 Loaded Patch Panels

- 24 Port 1U: PP2-2930/24S
- 48 Port 1U: PP2-4991/48S



#### Blank Patch Panels

- 24 Port 1U: PP3-4387/24S
- 24 Port 1U: PP3-4928/24AS
- 48 Port 2U: PP3-4929/48AS



### Optional Wall Plates

#### Metal Outdoor Wall Plates For Bulkhead RJ45 Jacks

These Industrial Grade Outdoor Wall Plates are the perfect for networking applications that require equipment to be in wet or debris-filled environments.



- 1-Port: WP10-3393/SG1P/SS
- 2-Port: WP10-1525/SG2P/SS

### Optional CAT6 Jack

#### CAT6 Outdoor Shielded Panel Mount Jack

These Outdoor Jacks are the perfect option for your networking applications that require equipment to be in wet or debris-filled environments.



- No Dust Cap: K66-1500-IP-SH
- With Dust Cap: K66-1729-IP-SH

### Optional CAT6 Outdoor Patch Cables

#### CAT6 Outdoor Shielded Patch Cable, 26 AWG, Black

Our CAT6 Industrial Outdoor Shielded Patch Cable is the perfect fit for outdoor applications. The durable UV-resistant jacket protects the cable from harsh exposure to sunlight. Additionally, the water-tight cap securely protects the high-quality shielded RJ45 connectors from dust and water.



- 3 ft: PC6O-1363-3BK
- 6 ft: PC6O-1364-6BK
- 10 ft: PC6O-1365-10BK
- 15 ft: PC6O-1366-15BK
- 25 ft: PC6O-1367-25BK
- 50 ft: PC6O-1368-50BK
- 75 ft: PC6O-1369-75BK
- 100 ft: PC6O-1370-100K
- 150 ft: PC6O-1676-150BK
- 200 ft: PC6O-6255-200BK

### Optional CAT6 Shielded Patch Cables

#### CAT6 Patch Cords Molded with Bubble

These 600MHZ CAT6 patch cables feature a 4 pair (8 conductors) 24AWG shielded (F/UTP) stranded copper cable and snag-less molded boots with bubble. These patch cables are professionally terminated with high quality RJ45 connectors featuring gold-plated contacts.



Multiple Colors Available

- 1 ft: PC6PS-2471-1BL
- 2 ft: PC6PS-2418-2BL
- 3 ft: PC6PS-2481-3BL
- 5 ft: PC6PS-2489-5BL
- 7 ft: PC6PS-2497-7BL
- 10 ft: PC6PS-2504-10BL
- 15 ft: PC6PS-2511-15BL
- 25 ft: PC6PS-2457-25BL
- 50 ft: PC6PS-2525-50BL
- 100 ft: PC6PS-2533-100BL

©2017 CRN Solutions Inc. dba. Primus Cable  
All Rights Reserved.

Although Primus Cable makes every reasonable effort to ensure their accuracy at the time of this publication, information and specifications described herein are subject to error or omission and to change without notice, and the listing of such information and specifications does not ensure product availability.

Primus Cable provides the information and specifications herein on an "AS IS" basis, with no representations or warranties, whether express, statutory or implied. In no event will Primus Cable be liable for any damages (including consequential, indirect, incidental, special, punitive, or exemplary damages) whatsoever, even if Primus Cable has been advised of the possibility of such damages, whether in an action under contract, negligence or any other theory, arising out of or in connection with the use, or inability to use, the information or specifications described herein.

All sales of Primus Cable products are subject to Primus Cable's standard terms and conditions of sale.

Primus Cable believes this product to be in compliance with EU RoHS (Directive 2002/EC, 27 Jan 2003). Material manufactured prior to the compliance date may be in stock at Primus Cable facilities and in our Distributor's inventory. The information provided in this Product Disclosure, and the identification of materials listed as reportable or restricted within the Product Disclosure, is correct to the best of Primus Cable's knowledge, information, and belief at the date any other operation of the product itself or the one that it becomes a part of. This Product Disclosure is not to be considered a warranty or quality specification and regulations based on their individual usage of the product.

Primus Cable declares this product to be in compliance with EU LVD (Low Voltage Directive 73/23/EEC), as amended by directive 93/68/EEC

PrimusCable.com - (951) 824-1571