

RouterBOARD 2011L series

Quick Setup Guide and Warranty Information

The RB2011L is a small form factor ethernet router with 5 Gigabit Ethernet ports and 5 Fast Ethernet ports. RB2011LS also includes a SFP module port (module not included). The RB2011L series includes five models, **RB2011L**, **RB2011L-IN** (Desktop case), **RB2011LS-IN** (Desktop case, SFP port) and **RB2011L-RM** (rackmount case) and **RB2011LS** (with SFP port).

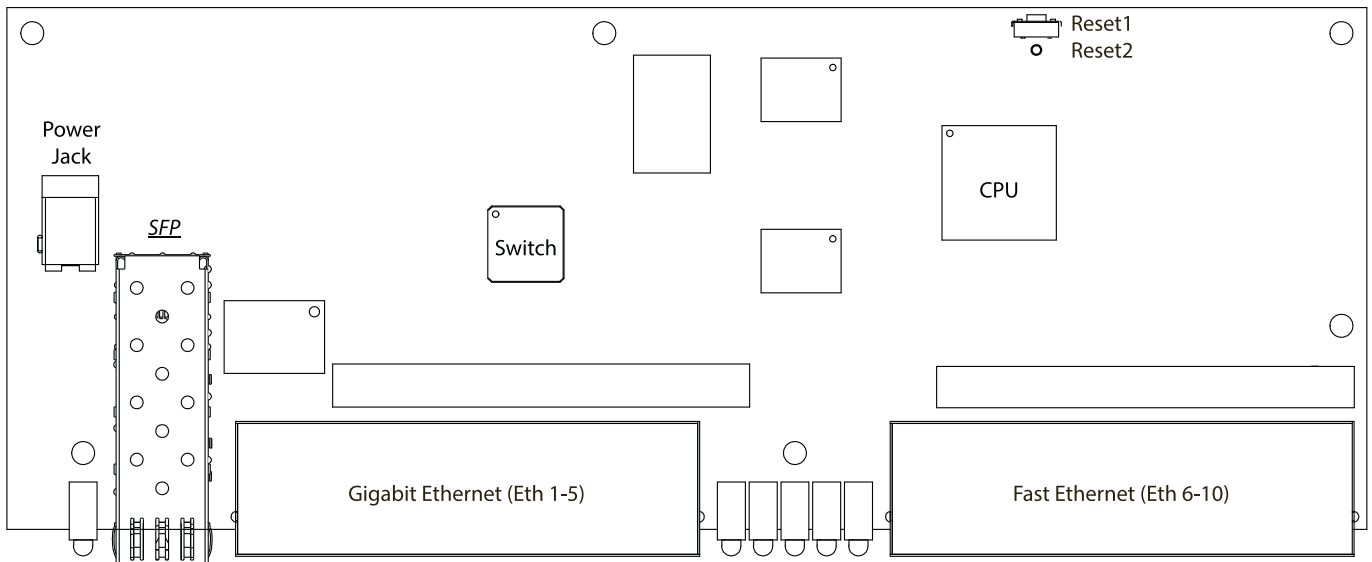

** SFP depends on model*

First use

The device comes preinstalled with RouterOS and is ready to use. RB2011 is compatible with RouterOS v5.9 and newer, if your device comes preinstalled with an earlier version, please upgrade before using it.

The Ethernet ports 2-10 have a default IP address for connecting: **192.168.88.1** username is **admin** and there is **no password**. Please connect with your web browser to this IP address and choose Webfig to configure it. **Ether1** is configured as a DHCP client, for connecting to your ISP.

See this page for connection and configuration guides: <http://wiki.mikrotik.com/wiki/Category:Manual>

Powering

The device accepts powering from either the power jack, or from the LAN1 Ethernet port:

- Direct-input power jack (5.5mm outside and 2mm inside diameter, female, pin positive plug) accepts 8-30V DC (overvoltage protection starts at 30V).
- Eth1 port accepts 8-30V DC input (at the board; higher voltage needed to compensate for power loss on long cables) from non-standard (passive) Power over Ethernet injectors. The board **does not** work with IEEE802.3af compliant 48V power injectors
- The IN and RM models include a 110/220V PSU which is already plugged into the power jack inside the case

Extension Slots and Ports

- Five 10/100/1000 (Gigabit) Ethernet ports (Auto MDI/X)
- Five 10/100 (Fast) Ethernet ports (Auto MDI/X)
- One 8-30V DC power jack
- (*RB2011LS only*) SFP port for SFP module (module not included)

Resetting the device

In case you wish to return the device to its original configuration, you can use the RESET button (image Reset1). Hold this button during boot time until LED lights start flashing, then release the button to **reset RouterOS configuration**. You can use this procedure if you have forgotten the password to access the device, or simply wish to return the unit to its default configuration state.

Buttons and Jumpers

- RouterBOOT reset button (image Reset1) has several functions:
 - ✓ Hold the button before powering on the device, and at power up, the button will force load the backup boot-loader. Continue holding the button for the other two functions of this button:
 - ✓ Release the button when green LED starts flashing, to reset RouterOS configuration. To not load backup boot-loader, you can start holding the button after power is already applied
 - ✓ Release the button after LED is no longer flashing (~20 seconds) to cause device to look for Netinstall servers (required for reinstalling RouterOS over network)
- RouterOS reset jumper hole (image Reset2): **resets RouterOS** software to defaults. Hold screwdriver pressed to this reset hole, and boot the device. Hold screwdriver in place until RouterOS configuration is cleared (10 seconds).

Operating System Support

Currently tested operating system is MikroTik RouterOS (starting from version 5.9).

Warranty

Copyright and Trademarks. Copyright MikroTik SIA. This manual contains information protected by copyright law. No part of it may be reproduced or transmitted in any form without prior written permission from the copyright holder. RouterBOARD, RouterOS, RouterBOOT and MikroTik are trademarks of MikroTik SIA. All trademarks and registered trademarks appearing in this manual are the property of their respective holders.

Hardware. MikroTik warrants all RouterBOARD series equipment for the term of fifteen (15) months from the shipping date to be free of defects in materials and workmanship under normal use and service, except in case of damage caused by mechanical, electrical or other accidental or intended damages caused by improper use or due to wind, rain, fire or other acts of nature.

To return failed units to MikroTik, you must perform the following RMA (Return Merchandise Authorization) procedure. Follow the instructions below to save time, efforts, avoid costs, and improve the speed of the RMA process.

1. If you have purchased your product from a MikroTik Reseller, please contact the Reseller company regarding all warranty and repair issues, the following instructions apply **ONLY** if you purchased your equipment directly from MikroTik in Latvia.
2. We do not offer repairs for products that are not covered by warranty. Exceptions can be made for RB1000, RB1100 and RB1200.
3. Out-of-warranty devices and devices not covered by warranty sent to MikroTik will be returned to the sender at sender's cost.

RMA Instructions are located on our webpage here: <http://rma.mikrotik.com>

Manual. This manual is provided "as is" without a warranty of any kind, expressed or implied, including, but not limited to, the implied warranty of merchantability and fitness for a particular purpose. The manufacturer has made every effort to ensure the accuracy of the contents of this manual, however, it is possible that it may contain technical inaccuracies, typographical or other errors. No liability is assumed for any inaccuracy found in this publication, nor for direct or indirect, incidental, consequential or other damages that may result from such an inaccuracy, including, but not limited to, loss of data or profits. Please report any inaccuracies found to support@mikrotik.com