

NOTES:

1. 1-1/2" x 1-1/2" TWO PIECE CONNECTOR USED FOR SPLICING CABLES AND RODS.
2. ACCOMMODATES ALL STANDARD SIZE CLASS I AND CLASS II CONDUCTORS UP TO 9/16" DIAMETER.
3. 5/16 x 1-3/4" STAINLESS STEEL CARRIAGE BOLTS, LOCK WASHERS AND NUTS INCLUDED.
4. A210 MANUFACTURED FROM HIGH CONDUCTIVITY ALUMINUM ALLOY

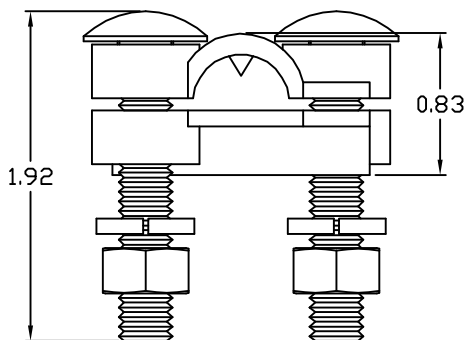
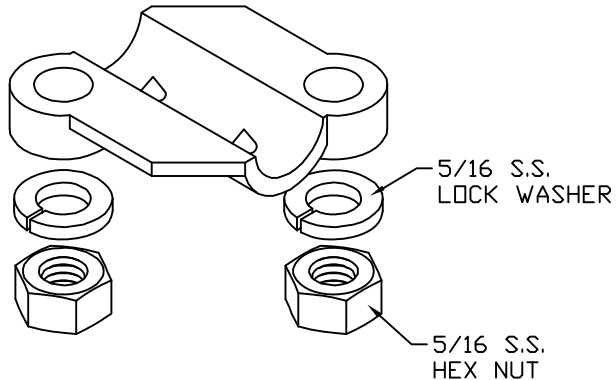

ASSEMBLY VIEW

EST WT 0.16#

ALUMINUM CROSS RUN CONNECTOR

APPROVED

AS DRAWN: \_\_\_\_\_  
 AS NOTED: \_\_\_\_\_  
 DATE: \_\_\_\_\_

THIS DOCUMENT AND THE CONTENTS THEREOF IS THE PROPERTY OF HARGER INC., AND IS FURNISHED TO YOU FOR INFORMATION ONLY. THE INFORMATION CONTAINED HEREIN IS CONFIDENTIAL AND OF A PROPRIETARY NATURE AND MUST NOT BE DISCLOSED TO THIRD PARTIES WITHOUT THE EXPRESS WRITTEN APPROVAL OF HARGER INC.

C	ECO 0057	102813	JKH
B	ZBOX WAS 1899	091903	WSM
A	ADD PACKAGE NOTE	080502	EHS
LET	REVISION	DATE	BY
TOLERANCES UNLESS NOTED:		3RD ANGLE PROJECTION	
FRACTIONAL	+/- 1/16		
.00	+/- .030		
.000	+/- .010		

PART NO. A210  
 CROSS RUN CONNECTOR

DRAWN BY: KAB  
 CHECKED BY: -  
 DATE: 031508



301 ZIEGLER DRIVE  
 GRAYSLAKE, IL 60030  
 (847) 548-8700

REVISION: C  
 SCALE: 7/8  
 SHEET: 1 OF 1