

POWERED BY



CM-30D-B

Chain Mount Base Kit, 8 ft chain

Dimensions

Pipe Outer Diameter	60.3 mm 2 3/8 in
Height	152.4 mm 6.0 in
Length	203.2 mm 8.0 in
Weight	17.6 kg 38.8 lb
Width	203.2 mm 8.0 in

Environmental Specifications

Man Rating	250 lb vertical man load at 15 mph (BWS)
Wind Rating	120 mph (BWS) at 100 ft AGL
Wind Rating Criteria	One 96 in x 10 in panel antenna per sector
Wind Rating Test Method	TIA/EIA-222

General Specifications

Product Type	Chain mount
Pipe, quantity	0
Package Quantity	1
Sectors, quantity	2

CM-30DB



Outline Drawing

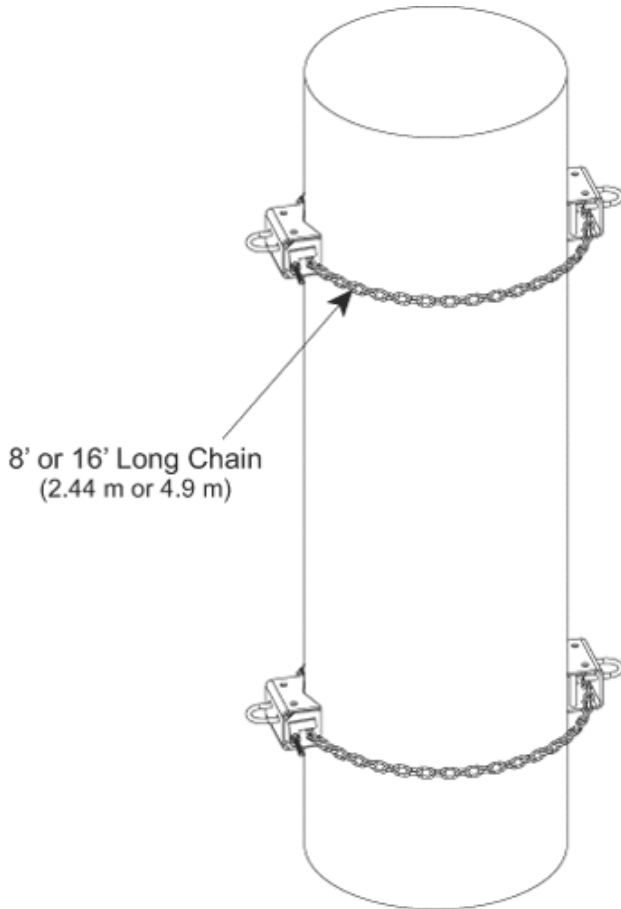

Regulatory Compliance/Certifications

Agency	Classification
ISO 9001:2008	Designed, manufactured and/or distributed under this quality management system

* Footnotes

Man Rating	BWS—Base Wind Speed
Wind Rating	BWS—Base Wind Speed; FBC—Florida Building Code