



UPS-AL48-900

900W UPSPro[®]

- Wireless Base Stations and Client Devices
- Surveillance Cameras
- Communications Towers
- Radio Towers



Congratulations! on your purchase of the UPSPro[®] 900W Backup Power System. Please take a moment to review this Qwik Install Guide before use. Please also review other user guides that are included in the package.

Operation Modes: AC/DC Grid, Solar Ready (May require blocking diode on solar panels)

Key Features: Industrial Strength, Weatherproof, Key Lock, 24VDC or 48VDC Output, 60A MPPT Battery Charge Controller, 72V 900W AC/DC Power Supply, 8640Wh Backup Capacity

Safety: For your own protection, follow these safety rules.

- **Perform as many functions as possible on the ground**
- **Do not attempt to install on a rainy, windy or snowy day or if there is ice or snow accumulation at the install site or if the site is wet.**
- **Make sure there are no people, pets, etc. below if you are working on a roof or ladder.**



Recommended Tools: Phillips and Small Flat Blade Screwdrivers, adjustable wrench



Please help preserve the environment and return any used batteries to an authorized depot

WARNING: 60A MPPT Controller is Positive Ground. Do Not Connect Battery Minus to Chassis Ground. Batteries should be floating. OK to connect controller ground screw to chassis ground.

Qwik Install

STEP 1: Prepare a foundation to provide level support for the enclosure.

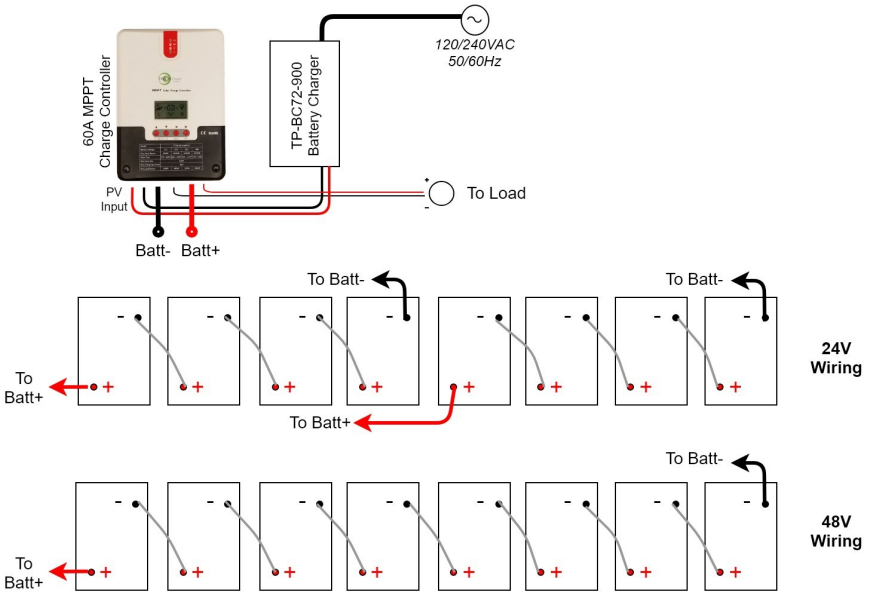

STEP 2: Place enclosure on the foundation. Install 8 batteries in the box. Use a rope tied to the battery tabs to lower batteries into the box. Connect all 8 batteries in series configuration for either 24VDC or 48VDC (See Wiring Diagram Below and near the end of this booklet)

STEP 3: Install DIN rail adapters to the 60A MPPT Battery Charge Controller.



STEP 4: Install DIN rail to enclosure using the two screws provided. Install MPPT battery charge controller to DIN Rail.

STEP 5: Remove the black cover from the MPPT controller to access the wire connection screws. Connect the temperature probe to the controller and place it on one of the batteries for temperature compensated charging.

STEP 6: Remove the fuses from the battery cables and connect the battery cables to the batteries and the MPPT Charge Controller BAT+ and BAT- connections.

STEP 7: Make sure to set the AC input voltage selector on the 72V 900W AC/DC Power Supply to either 115 or 230 depending on your AC voltage source. The 900W Power Supply can sit in the bottom of the enclosure next to the batteries. Connect the Power Supply DC output wires to the MPPT Charge Controller PV+ and PV- inputs. The Brown wire is V+. Make sure to observe proper polarity.

STEP 8: Connect normal loads to the MPPT Charge Controller load output. Maximum load is 20A Max. If connecting an inverter or motor, it's best to connect directly to the batteries.

STEP 9: Double check connections and then re-install the fuses in the battery cables. You may see a spark when connecting the fuse. This is normal. Once the MPPT charge controller is connected to the batteries, it's display should turn on and you will see status on the screen.

Warning: Battery should always be connected first and disconnected last from the MPPT charge controller.



STEP 10: Route any external wires through the cable glands on the back of the enclosure. Tighten the cable glands on the wires to make weatherproof connections. Plug unused holes using the supplied hole plugs. If any cable glands are installed but unused, cut a short piece of wire and tighten in the cable gland to seal it.

If desired, attach a security cable/chain through the features on the back of the enclosure to an existing pole/tree.

STEP 11: To turn on the load output, long press the SET button on the MPPT charge controller. Turn on the 72V 900W AC/DC power supply. The MPPT charge controller will show PV input is active and the batteries will start charging after 1-2 minutes. When the AC/DC power supply is charging, both LED will be red and the unit fan will come on. This is normal. When the batteries are fully charged the 72V 900W charger will go into standby mode and one LED will turn green.

STEP 12: The enclosure comes with a thermostatically (45C) controlled ventilation fan. Connect this fan directly to the batteries.

Specifications

Battery Voltage (DC)	24V or 48V (customer configure)
Input Voltage (AC)	120/240VAC, 50/60Hz, 5A Max.
Capacities (Amp Hr)	24V 360Ah, 48V 180Ah
Avail Storage Capacity (WHr)	8640Wh
Max Output Power	900W
Suggested Max Load	750W
MaxInstantaneous Load	20A 500msec
Battery Type	Valve Regulated Sealed Lead Acid / GEL
Battery Life	5 years
Battery Cable Fuse	6 x 32mm Ceramic 30A 250V
Controller Type	60A MPPT Solar Controller with Status Display and 20A Load with on/off switch
MaxSolar Panel Size	1600W @ 24V Battery, 3200W @ 48V Battery
Controller Display Status	Battery Voltage, Charging Voltage, Charging Current, Load Current, Temp
Bulk Charge	28.8V @ 24V Battery, 57.6V @ 48V Battery
Float Charge	27.6V @ 24V Battery, 55.2V @ 48V Battery
Over-discharge protection	22V @ 24V Battery, 44V @ 48V Battery
Over-discharge recovery volts	25.2V @ 24V Battery, 50.4 @ 48V Battery
Controller Self Consumption	<1.2W
Enclosure Type	Ground Mount, Key Lock, Aluminum Diamond Plate
Enclosure External Size	68" x 19" x 25" (1732 x 483 x 635mm)
Operating Temperature	-40°C to +65°C (-40°F to 149°F)
System Weight (without batteries)	78lbs (35kg)
Battery Weight	8 x 68lbs (31kg)
Certifications	Individual components used have CE Certifications. Batteries have CE and UL.
Warranty	3 Years

TECH CORNER

Additional Information you may find useful

Solar Ready: The system is solar ready. You may need to add a 100V 30A blocking diode (Tycon pn 5600059) between the solar panel and the PV input to avoid reverse current from the 72V AC/DC power supply going back into the solar panels.

Batteries: The batteries are maintenance free and should last about 5 years in normal operation. The charge controller will automatically do a balance charge on the batteries periodically.

Enclosure: We recommend making extra keys in case the enclosure keys are lost.

NOTES

Accessories

TP-SC-BT1 RS232 to Bluetooth adapter.

- Allows for wireless monitoring and control of the MPPT solar charge controller up to 15m.
- Uses a smartphone app available for Android and IOS devices
- Completely weatherproof for outdoor mounting
- Low Cost



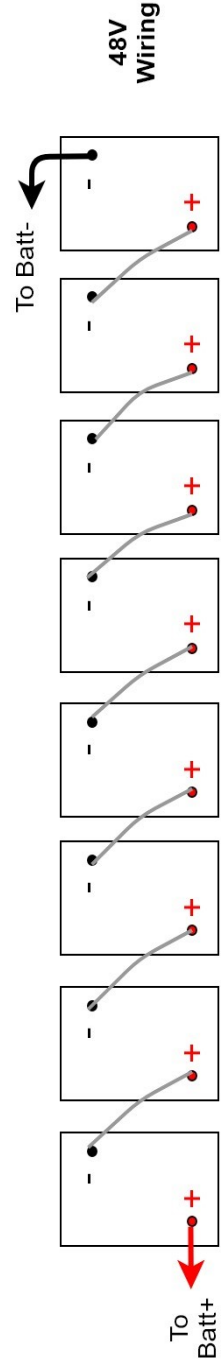
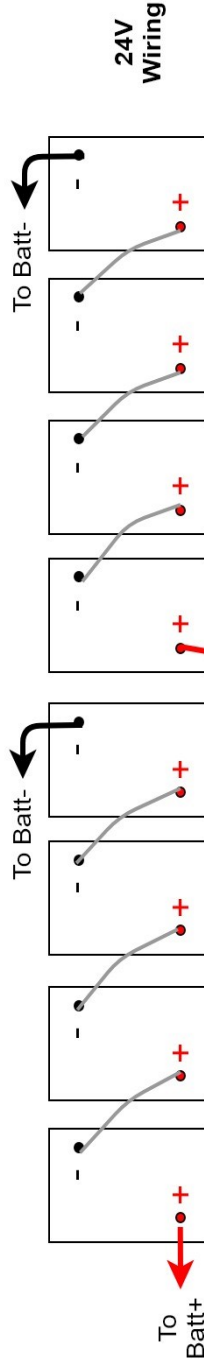
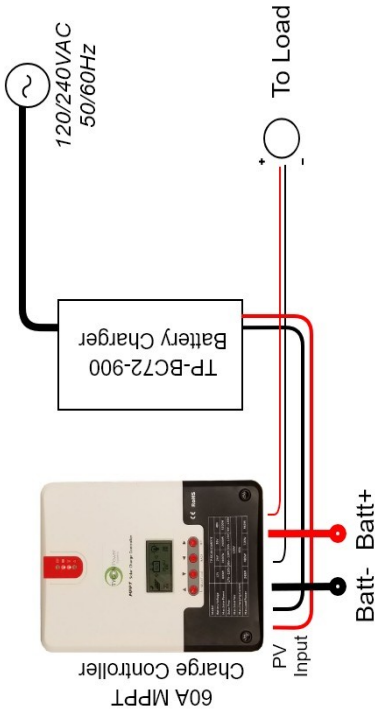

Remote Station Monitor

TPDIN-Monitor-WEB2

- Qty 4: Voltmeters and current meters
- Web Based: allows station monitoring over the internet.
- Qty 4: 10A relays for controlling power to devices, starting a generator, etc.
- Measures internal and external temperatures
- Intuitive user interface and graphical set-up
- SNMP compatibility
- Shunt compatible for measuring very high currents
- Email Alerts
- Programmable functionality



Limited Warranty

The UPSPro[®] Backup Power System is supplied with a limited 36 month warranty which covers material and workmanship defects. This warranty does not cover the following:

- Parts requiring replacement due to improper installation, misuse, poor site conditions, faulty power, etc.
- Lightning or weather damage.
- Physical damage to the external & internal parts.
- Products that have been opened, altered, or defaced.
- Water damage.
- Usage other than in accordance with instructions and the normal intended use.

Tycon Systems Inc.
14641 S 800 W Suite A
Bluffdale, UT 84065
support@tyconsystems.com
PH: 801-432-0003

