



### Aluminum Outdoor Enclosures

#### Features

- Weatherproof Nema 4X / IP65, UV resistant, outdoor enclosures
- Ventilated, Gasket Sealed and Lockable Using Padlocks
- Supports up to 200Ah of Battery
- Built in Mounting for DIN Rails on Inside Door and Back
- Built in DIN Rails on Inside Left and Right Sides
- Weatherproof Cable Feedthroughs
- Thermostatically Controlled Ventilation
- Wall and Pole Mountable (Includes Mounting Hardware)

#### Applications

- Wireless Base Stations and Clients
- Surveillance Cameras
- Wireless Bridge and Repeaters
- Remote Sensors
- Outdoor Utilities
- Solar and Wind Power

#### Description

The ENC-AL-21x14x15 and ENC-AL-12x14x15 outdoor enclosures are designed for applications that require a lightweight, sturdy, weatherproof enclosure to house various electronics. They have gasket seals and are made from UV and corrosion resistant materials for long service life. They can be wall or pole mounted with the included U-Bolts. The heavy-duty pole mounting can accommodate up to a 4" diameter pole. For larger diameter poles, stainless steel straps are available commercially to accommodate almost any diameter pole.

The enclosure is designed to be passively ventilated and also includes a thermostatically controlled ventilation system that runs on 12VDC – 24VDC and turns on when interior temperature exceeds 45C.

Enclosure can be securely locked. Door closures are two stainless draw latches that can accommodate up to 9mm (0.35") diameter user supplied padlock.

Inside the enclosure are short DIN rails welded on the left and right walls. Din Rail mounting brackets are also available behind the shelf and on the door for mounting additional equipment. These DIN Rail mounting brackets can also be used for mounting a metal or wooden panel if desired. There are two battery shelves in the 21" enclosure to hold up to 200Ah of battery and a single battery shelf in the 12" enclosure that holds up to 100Ah of battery.

The enclosure comes with 3 RJ45 Feedthru cable glands for weatherproof cable entry/exit. The cable glands are mounted in the bottom of the enclosure on a removeable gasketed access plate.

The enclosure is corrosion resistant for long service life. Enclosure material is powder coated aluminum. All hardware is stainless steel.



ENC-AL-21x14x15  
Aluminum Enclosure



ENC-AL-12x14x15  
Aluminum Enclosure

## Specifications

	ENC-AL-12x14x15	ENC-AL-21x14x15
<b>Enclosure Type</b>	Powder Coated Aluminum	
<b>Weatherproofing</b>	Nema 4X / IP65	
<b>Enclosure Mounting</b>	Wall or pole mount with U Bolt or hose clamps	
<b>Interior Mounts</b>	4" Long Din Rails(4), Din Rail Mounts(4)	
<b>Enclosure External Size (LxWxD)</b>	12 x 14 x 15" (305 x 356 x 381mm)	21 x 14 x 15" (533 x 356 x 381mm)
<b>Weight</b>	20lb (9kg)	26lb (12kg)
<b>Warranty</b>	3 Years	
		

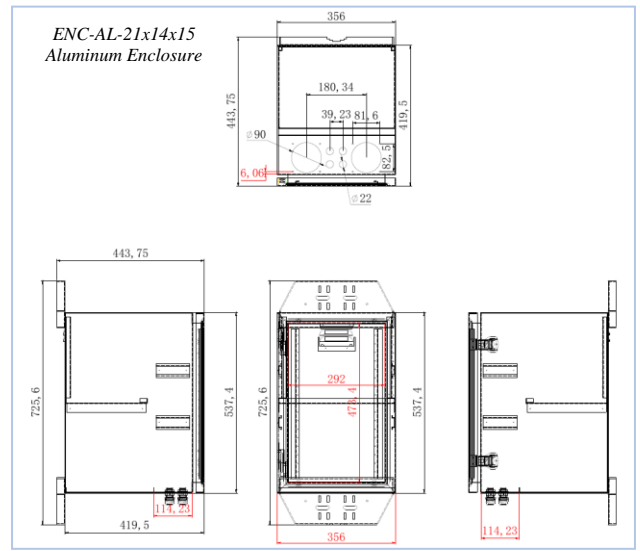
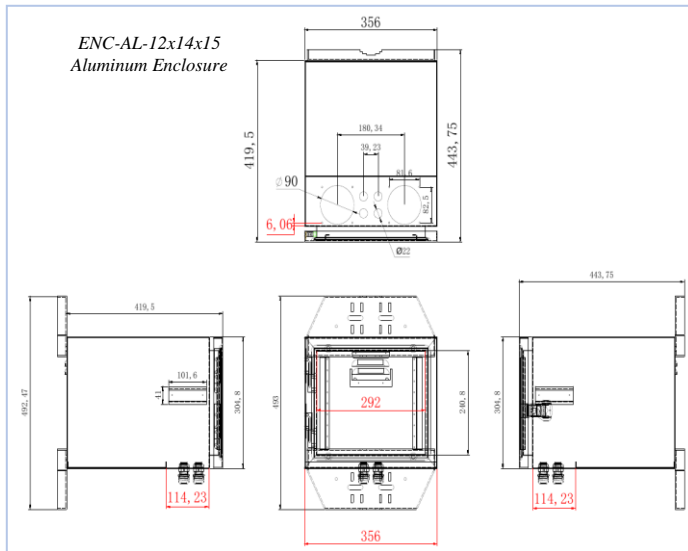

### System Ordering:

**ENC-AL-12x14x15** Outdoor Powder Coated Aluminum Enclosure for 2 batteries, 12x14x15"

**ENC-AL-21x14x15** Outdoor Powder Coated Aluminum Enclosure for 4 batteries, 21x14x15"

For further information contact:

[Tyconsystems.com](http://Tyconsystems.com)

