

Proprietary rights are included in the information disclosed herein. This information is submitted in confidence and neither the document nor the information disclosed here-in shall be reproduced or transferred to other documents for manufacturing or for any other purpose except as specifically authorized in writing by ARE Telecom & Wind.

REVISIONS			
REV.	DESCRIPTION	DATE	APPROVED
A	initial release	6/25/18	MGC

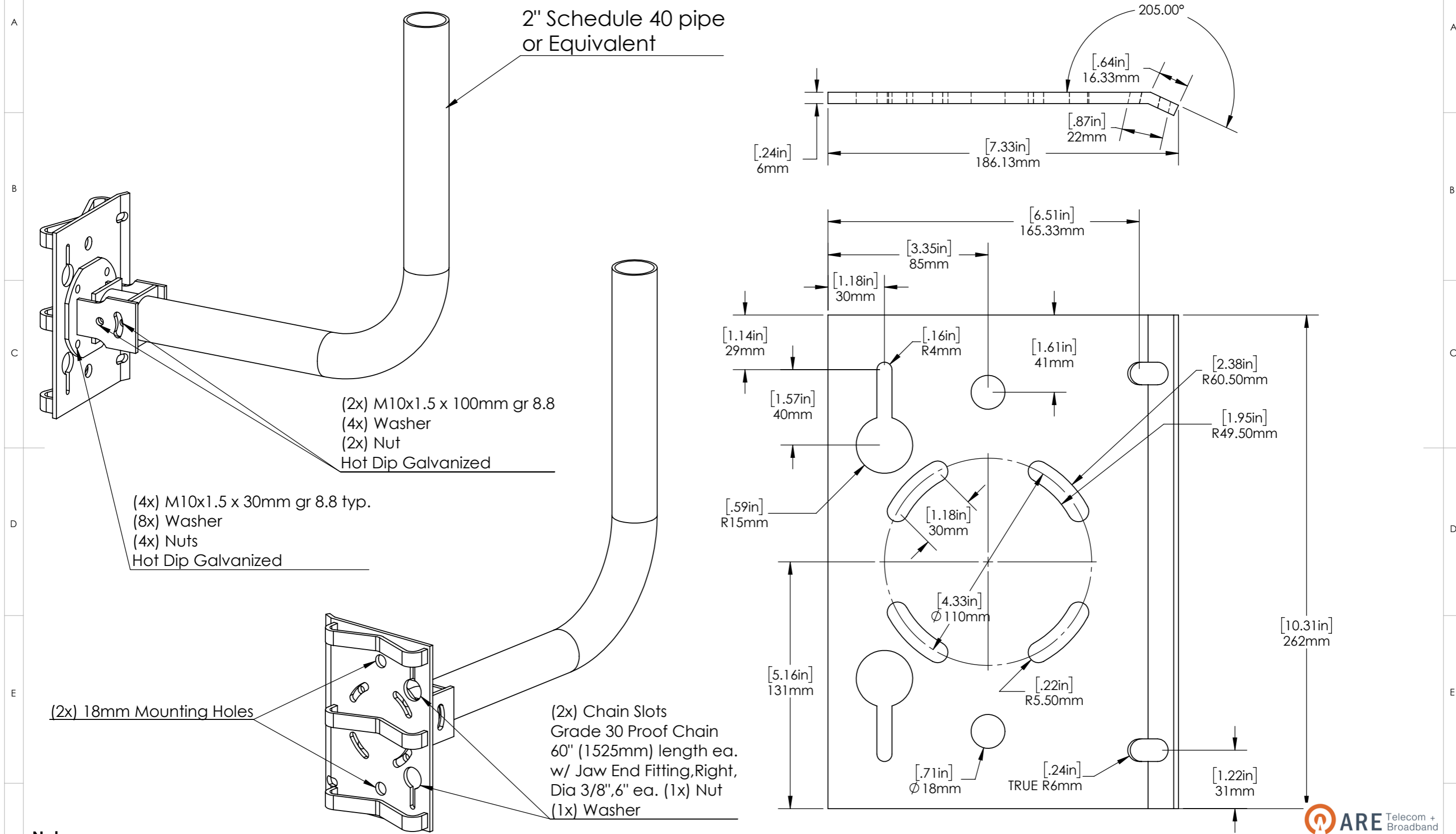

- Notes:**
1. All plate material shall have a minimum yield strength of 345 MPa (50 ksi)
 2. Pipe or Tube shall have a minimum yield strength of 345 MPa (50ksi)
 3. All welding shall conform to the minimum requirements of AWS D1.1
 4. All welding shall be done by welders qualified under AWS specifications, using E80XX, low hydrogen electrodes
 5. Adaptor shall be Hot Dip Galvanized in accordance with ASTM A123
 6. Deburr all sharp edges

Weight 9.5 kg (21 lbs)	CAD-generated drawing do not manually update		ARE Telecom + Broadband 1043 Grand Avenue, # 213 St. Paul, MN 55105 (651) 330-1263
	APPROVALS DRAWN MGC CHECKED RESP ENG MFG ENG QUAL ENG	DATE 6/25/18	
MATERIAL See Notes FINISH See Notes DO NOT SCALE DRAWING	scale NA rev. A size NA 1 of 4		

Proprietary rights are included in the information disclosed herein. This information is submitted in confidence and neither the document nor the information disclosed here-in shall be reproduced or transferred to other documents for manufacturing or for any other purpose except as specifically authorized in writing by ARE Telecom & Wind.

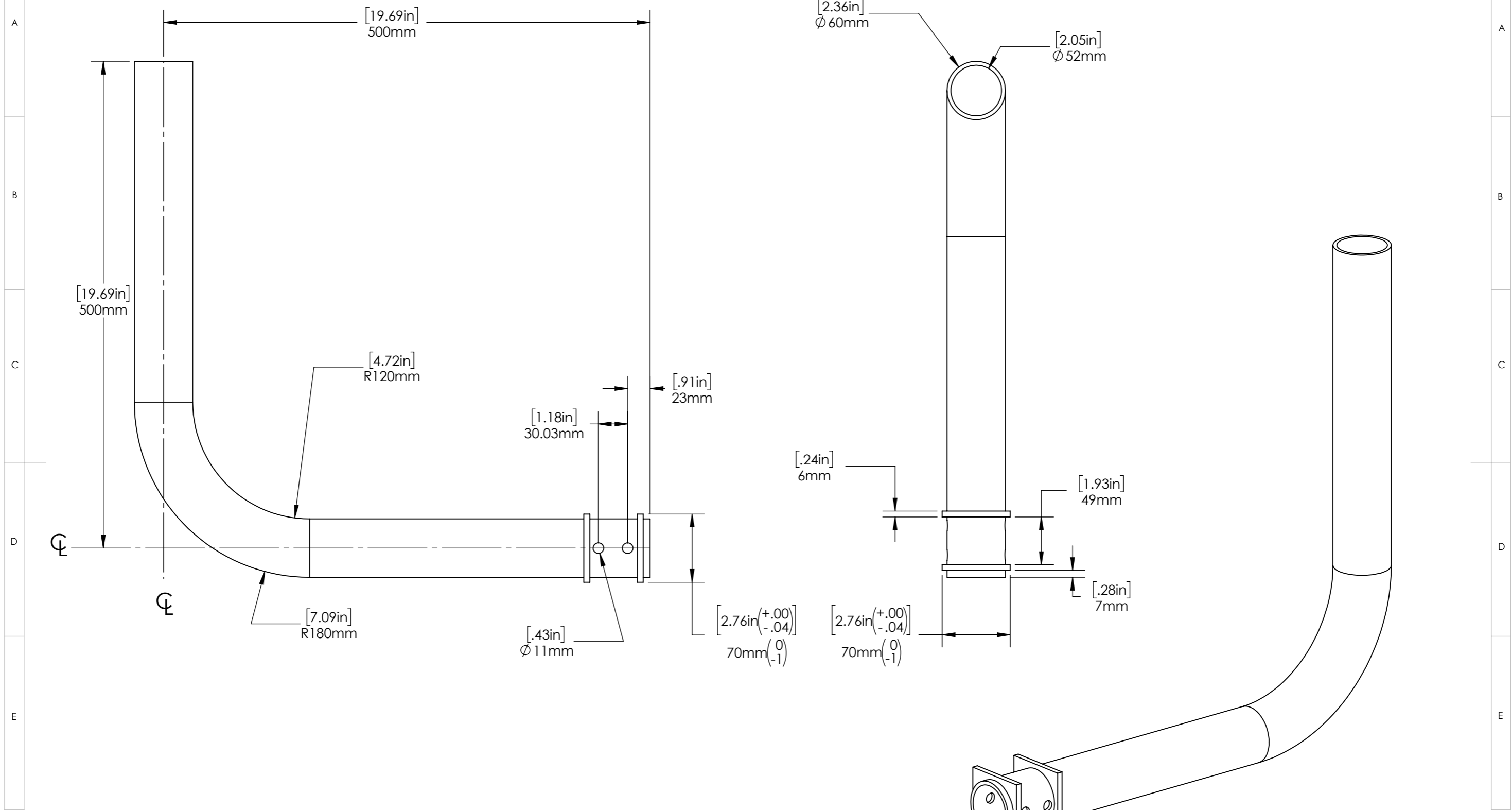

Notes:

1. All plate material shall have a minimum yield strength of 345 MPa (50 ksi)
2. Pipe or Tube shall have a minimum yield strength of 345 MPa (50ksi)
3. All welding shall conform to the minimum requirements of AWS D1.1
4. All welding shall be done by welders qualified under AWS specifications, using E80XX, low hydrogen electrodes
5. Adaptor shall be Hot Dip Galvanized in accordance with ASTM A123
6. Debur all sharp edges



ARE Telecom & Wind
1043 Grand Avenue, # 213
St. Paul, MN 55105
(651) 330-1263

Antenna Mount

Part #
scale NA rev. A size NA sheet 2 of 4

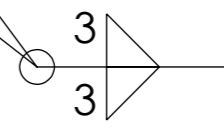

Proprietary rights are included in the information disclosed herein. This information is submitted in confidence and neither the document nor the information disclosed herein shall be reproduced or transferred to other documents for manufacturing or for any other purpose except as specifically authorized in writing by ARE Telecom & Wind.

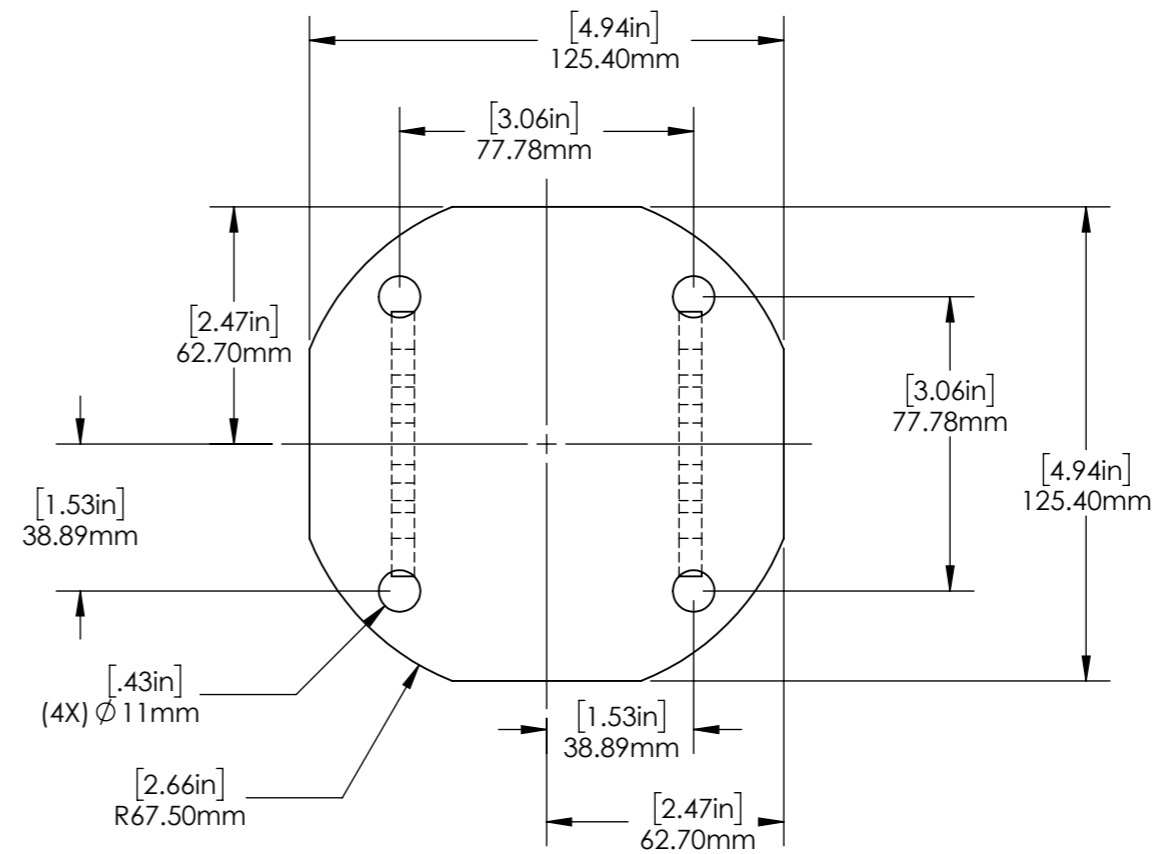
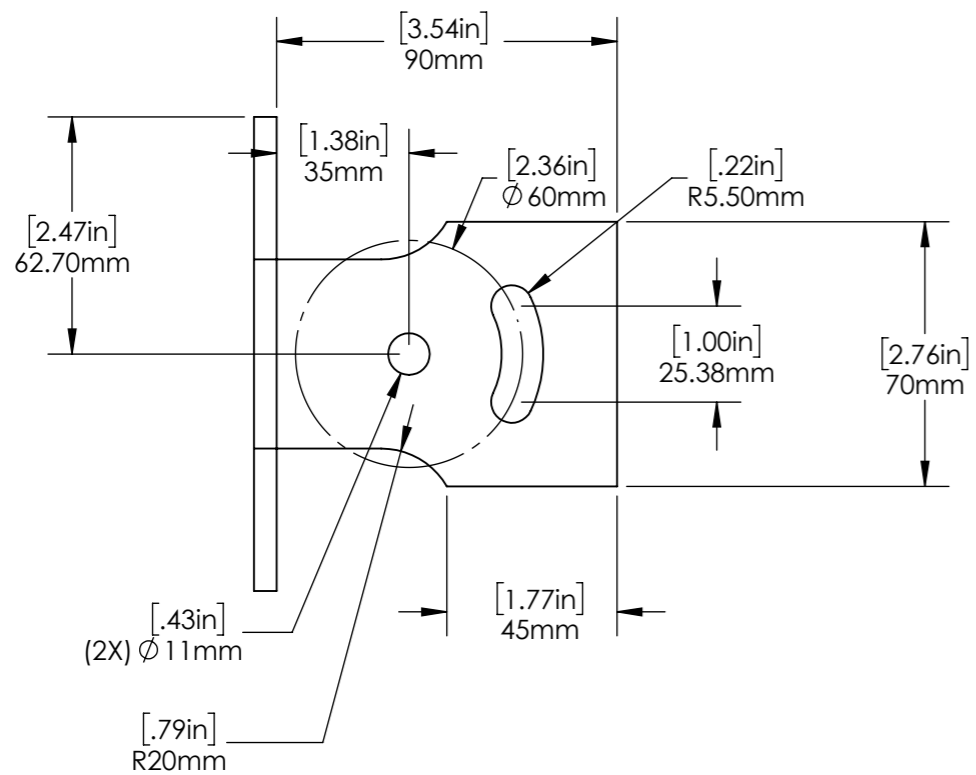
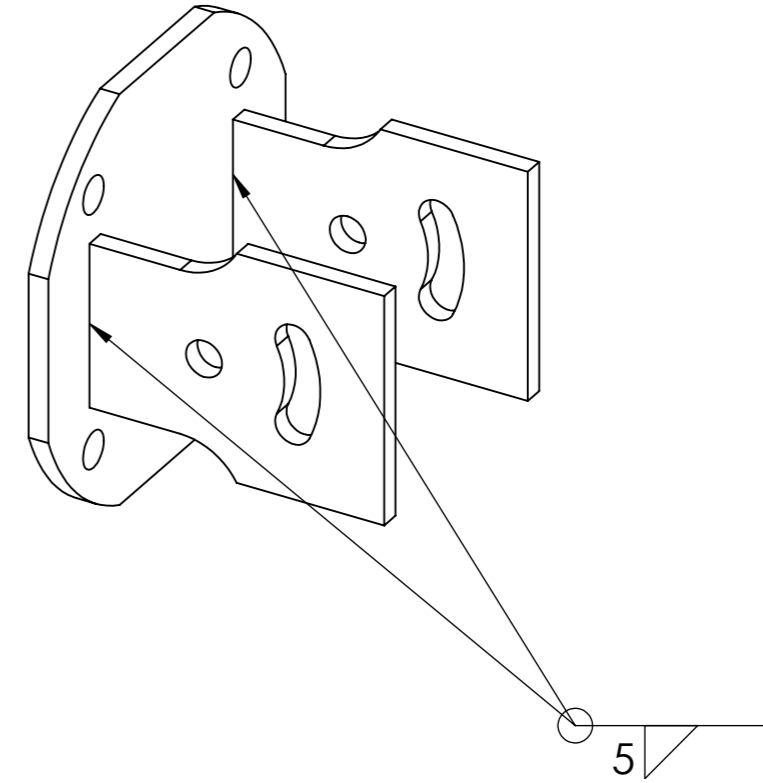
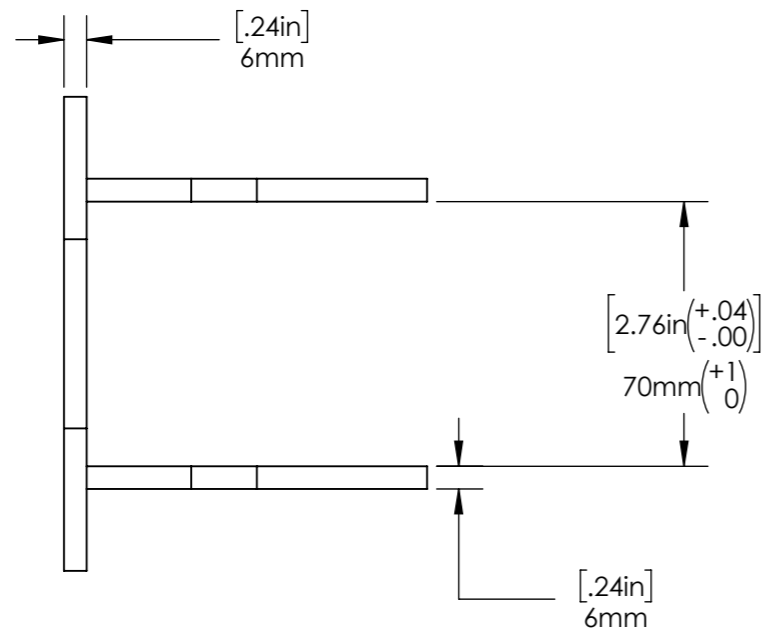

Notes:

1. All plate material shall have a minimum yield strength of 345 MPa (50 ksi)
2. Pipe or Tube shall have a minimum yield strength of 345 MPa (50ksi)
3. All welding shall conform to the minimum requirements of AWS D1.1
4. All welding shall be done by welders qualified under AWS specifications, using E80XX, low hydrogen electrodes
5. Adaptor shall be Hot Dip Galvanized in accordance with ASTM A123
6. Deburr all sharp edges



ARE Telecom & Wind
1043 Grand Avenue, # 213
St. Paul, MN 55105
(651) 330-1263

Antenna Mount

Part # ☐
scale NA rev. A size NA sheet 3 of 4

Proprietary rights are included in the information disclosed herein. This information is submitted in confidence and neither the document nor the information disclosed herein shall be reproduced or transferred to other documents for manufacturing or for any other purpose except as specifically authorized in writing by ARE Telecom & Wind.

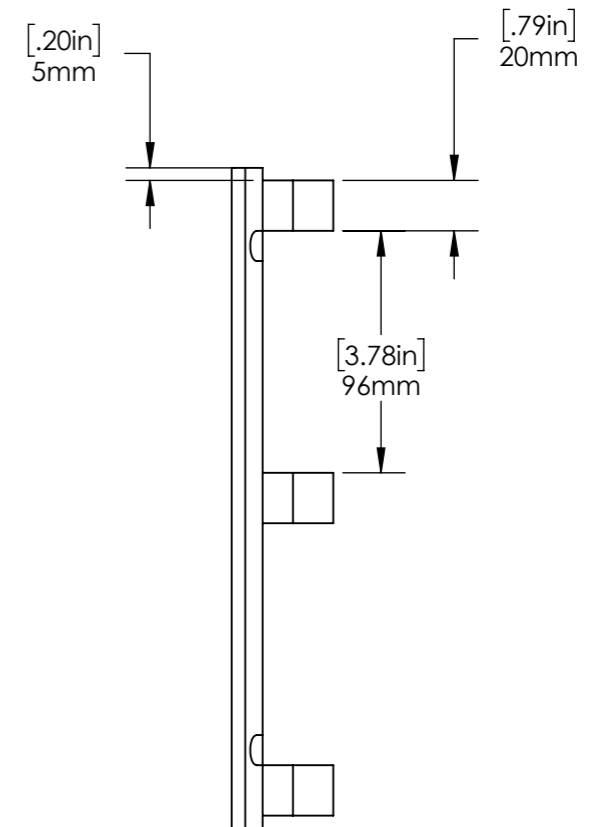
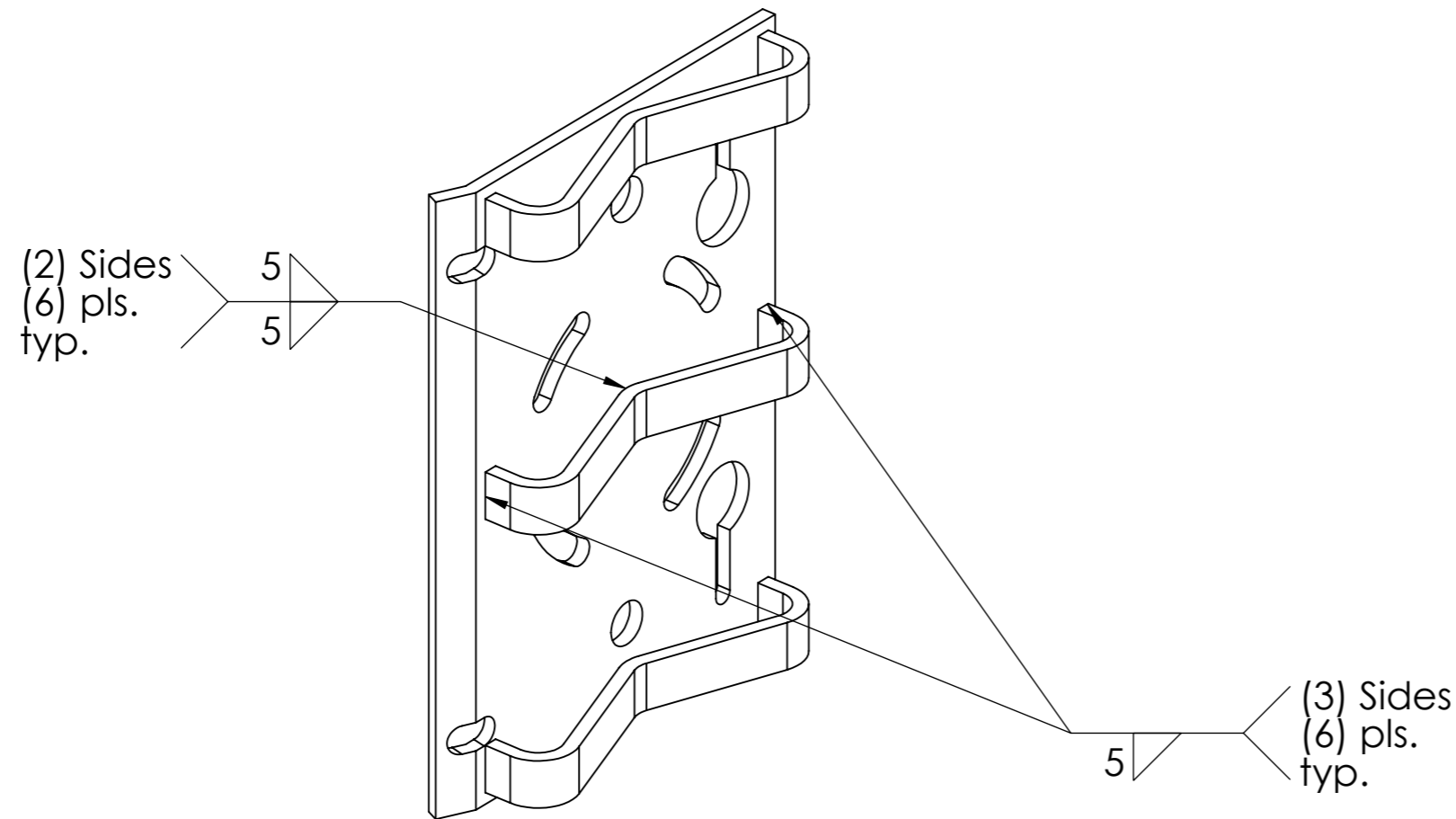
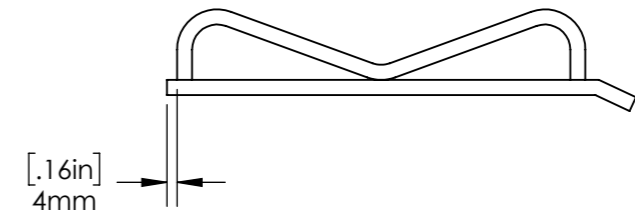
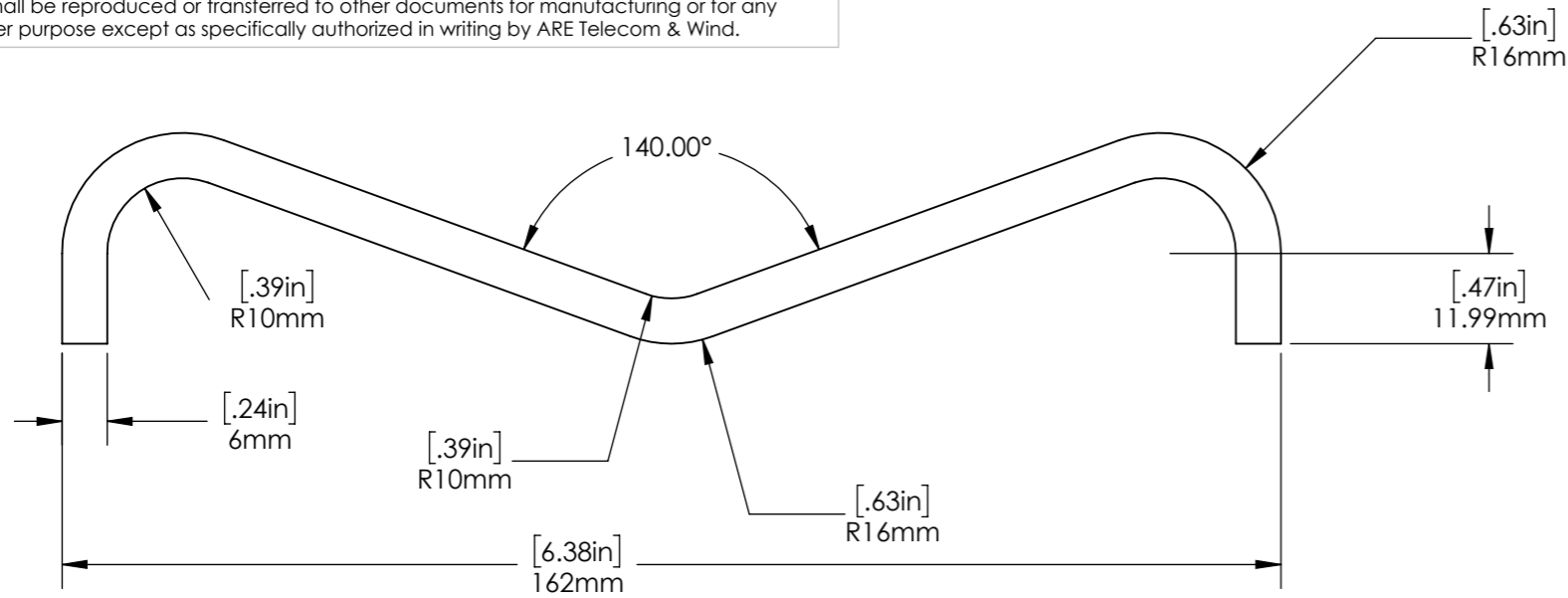

Notes:

1. All plate material shall have a minimum yield strength of 345 MPa (50 ksi)
2. Pipe or Tube shall have a minimum yield strength of 345 MPa (50ksi)
3. All welding shall conform to the minimum requirements of AWS D1.1
4. All welding shall be done by welders qualified under AWS specifications, using E80XX, low hydrogen electrodes
5. Adaptor shall be Hot Dip Galvanized in accordance with ASTM A123
6. Debur all sharp edges



ARE Telecom & Wind
1043 Grand Avenue, # 213
St. Paul, MN 55105
(651) 330-1263

Antenna Mount

Part # 
scale NA rev. A size NA sheet 4 of 4